

# INSTRUCTIONS

AIR-LOC

## PLATE STYLE MANHOLE TESTER WITH 1-1/2" VACUUM HOSE ASSY.

PART NUMBERS 220-328, 220-388, 220-448.

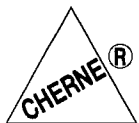
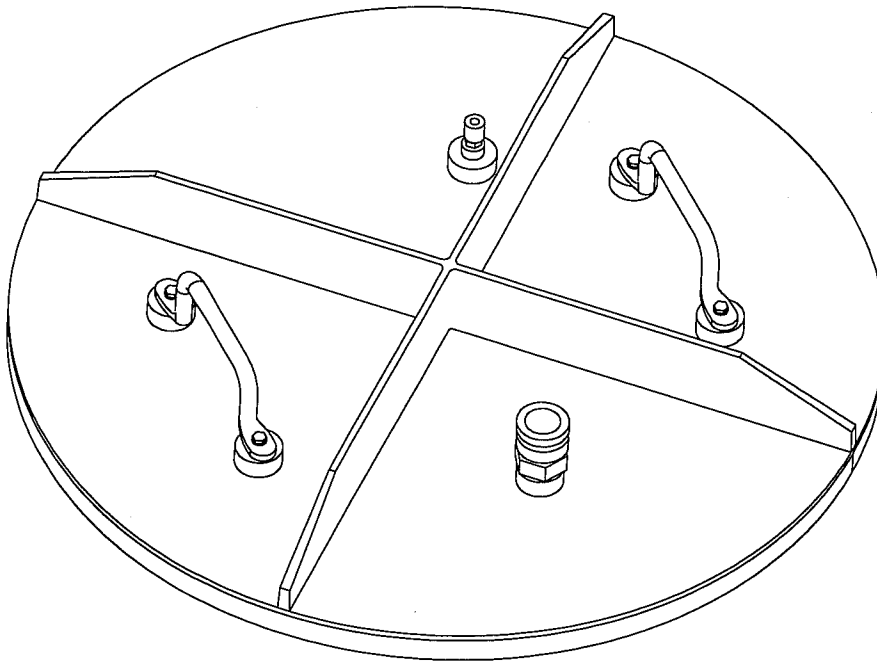

CHERNE INDUSTRIES INCORPORATED  
5700 LINCOLN DRIVE  
MINNEAPOLIS, MN 55436

1-800-THE PLUG  
(1-800-843-7584)  
FAX: 1-800-843-7585  
[www.cherneind.com](http://www.cherneind.com)

## TABLE OF CONTENTS

Unpacking.....Page 2

Safety.....Page 3-4

Preparing the Manhole.....Page 4

Installation & Operation.....Page 5-6

Parts List.....Pages 7-10

Manhole Safety Procedure.....Page 11

Limited Warranty.....Page 12

### **UNPACKING**

Inspect this product immediately upon receipt. If you find damage, notify the delivering carrier immediately to begin the claims process. Carriers have the right to refuse claims for damage if they are not notified immediately.

**NOTICE: THIS PRODUCT HAS NOT BEEN TESTED UNDER ALL FIELD CONDITIONS. IT IS THE CUSTOMER'S RESPONSIBILITY TO DETERMINE THE SUITABILITY FOR SPECIFIC APPLICATIONS. CHERNE INDUSTRIES INCORPORATED ASSUMES NO RESPONSIBILITY THAT THIS PRODUCT IS SUITABLE FOR ALL VACUUM TESTING CONDITIONS.**

## **INTRODUCTION**

The Cherne Manhole Tester is used for testing the integrity of manholes and their resistance to water infiltration/exfiltration using vacuum as a test medium. The manhole's integrity is checked by measuring the vacuum loss over a specified time. If too much vacuum is lost, the manhole is defective and must be repaired.

This manual will help you install and operate the Manhole Tester. Parts lists of the test heads are included if it becomes necessary to order replacement parts.

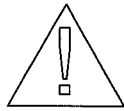

## WARNING

Test manholes for gases before using the Manhole Tester. Ventilate the manhole if toxic or flammable gases are present - they can cause injury, asphyxiation, or death! If the sewer system has hazardous gases from sewage or solvents, the Manhole Tester may draw them into the manhole during the vacuum operation. Test again for gases after the vacuum operation if you plan on entering the manhole.

1. Observe all state and federal regulations when entering manholes.
2. Follow the Manhole Safety Procedure at the end of this manual.
3. Brace the pipeline inverts if the lines entering the manhole have not been back-filled. This will prevent the pipe from dislodging and being pulled into the manhole.
4. Make sure the ball valve is closed before starting the vacuum pump/generator.
5. Always disconnect the spark plug wire or air supply before servicing the vacuum pump or vacuum generator.
6. Wear a safety hat, safety glasses, and ear protection during operation.
7. Make sure the Manhole Tester is properly centered on the manhole opening-otherwise the plate may collapse and injure the operator.

## PREPARING THE MANHOLE

1. Plug all openings inside the manhole with properly sized pneumatic or mechanical plugs.
2. Brace the pipeline inverts if the lines entering the manhole have not been back-filled. This will prevent the pipe from dislodging and being pulled into the manhole.

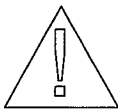

## WARNING

FOLLOW ALL MANUFACTURER RECOMMENDATIONS AND WARNINGS REGARDING SAFE AND PROPER INSTALLATION OF SUCH PLUGS. MAKE SURE THE PLUGS ARE PROPERLY RATED FOR THE PRESSURES REQUIRED IN THE TEST. THE STANDARD TEST OF 10 INCHES MERCURY EQUALS ABOUT 5 PSIG (0.3 BAR) BACK-PRESSURE. CHERNE INDUSTRIES INCORPORATED RECOMMENDS USING PLUGS RATED FOR TWICE THAT BACK-PRESSURE (10 PSIG or 0.7 BAR). AND BE BLOCKED.

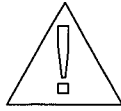

## DANGER!

Never operate the manhole tester while a person is inside the manhole. This may result in serious bodily injury or death!

### INSTALLATION AND OPERATION

1. Remove manhole cover and place manhole tester over top opening. **Caution: Make sure manhole tester's plate overlaps manhole frame or chimney evenly on all sides.**

Note: For best results, pre-test manhole before back-filling.

2. Attach vacuum hose to coupling located on top of Manhole Tester.

3. Vacuum pump or vacuum generator:

- Make sure the ball valve is closed.
- Vacuum pump: Start engine and set to correct rpm.
- Vacuum generator: Attach air supply hose making sure that air supply is shut off before connecting. Turn on air supply to vacuum generator.

4. Open ball valve and evacuate manhole to 10" Hg. (usual vacuum test is 10" Hg.).

5. Close ball valve and monitor the vacuum for the specified test period--use the following chart:

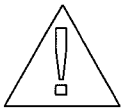
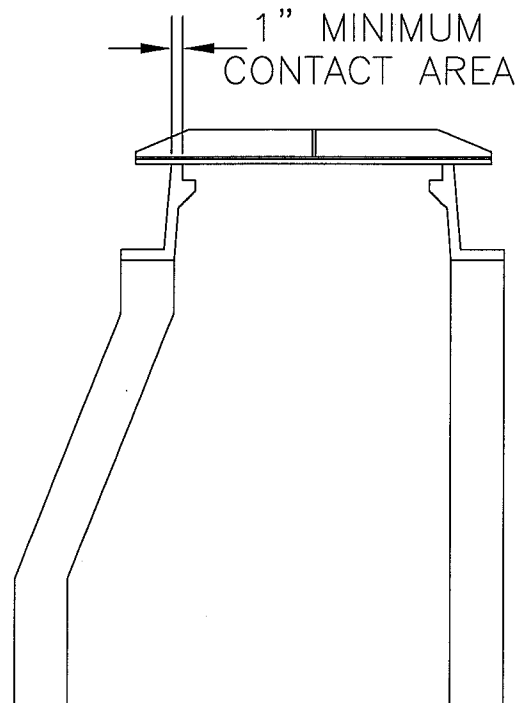

## WARNING!

Manhole tester can suddenly shoot upwards. This can happen if the plugs suddenly dislodge for any reason. As the plugs move they can pressurize the manhole causing the tester to shoot upwards suddenly. This may cause death, severe injury and/or property damage.

DEPTH (FEET) MANHOLE LENGTH	TIME (SECONDS)		
	48 INCH	60 INCH	72 INCH
8	20	26	33
10	25	33	41
12	30	39	49
14	35	46	57
16	40	52	65
18	45	59	73
20	50	65	81
22	55	72	89
24	59	78	97
26	64	85	105
28	69	91	113
30	74	98	121

**NOTE:** These numbers have been taken from ASTM designation C1244.

6. If vacuum drops less than 1" Hg. within test time, manhole is considered acceptable and passes test. If manhole fails and leaks, make needed repairs and test again until satisfactory results are obtained.
7. Repeat this manhole test after back filling.
8. To disconnect vacuum generator/pump from manhole tester: Depressurize the compressor output hose or shut down vacuum pump, open ball valve, disconnect the vacuum pumps/generator when the vacuum gauge reads zero.

#### **TROUBLE-SHOOTING:**

If the manhole fails the test, identify the leaking areas by removing the head assembly, coating the interior surfaces of the manhole with a soap and water solution, and repeating the vacuum test for approximately sixty seconds. Leaking areas will have soapy bubbles. Once the leaks have been identified, complete all necessary repairs and repeat test procedures until satisfactory results are obtained.

If the Manhole Tester does not seal over the manhole top, try wetting the surface area in contact with the Manhole Tester's foam pad, or placing weight on the Manhole Tester plate to compress gasket.

**PARTS LIST 32"  
ASSEMBLY #220-328**

ITEM	QUANTITY	PART NO.	DESCRIPTION
1	1	030-718	FOAM PAD, 32" DIAMETER
4	1	054-308	1-1/2" COUPLER, CAM AND GROOVE
6	1	019-125	TEST PLATE, 32" MANHOLE
10	1	054-978	1/4" QUICK-COUPLER
9	2	002-388	HANDLE, GRAB 8" CENTER-ZINC
11	1	056-978	INSTRUCTION (THIS MANUAL)
13	4	000-132	WASHER, 1/4 LOCK
15	4	000-396	BOLT, MHH, 1/4-20 X 1
16	1	055-348	1-1/2" VACUUM HOSE W/VACUUM GAUGE

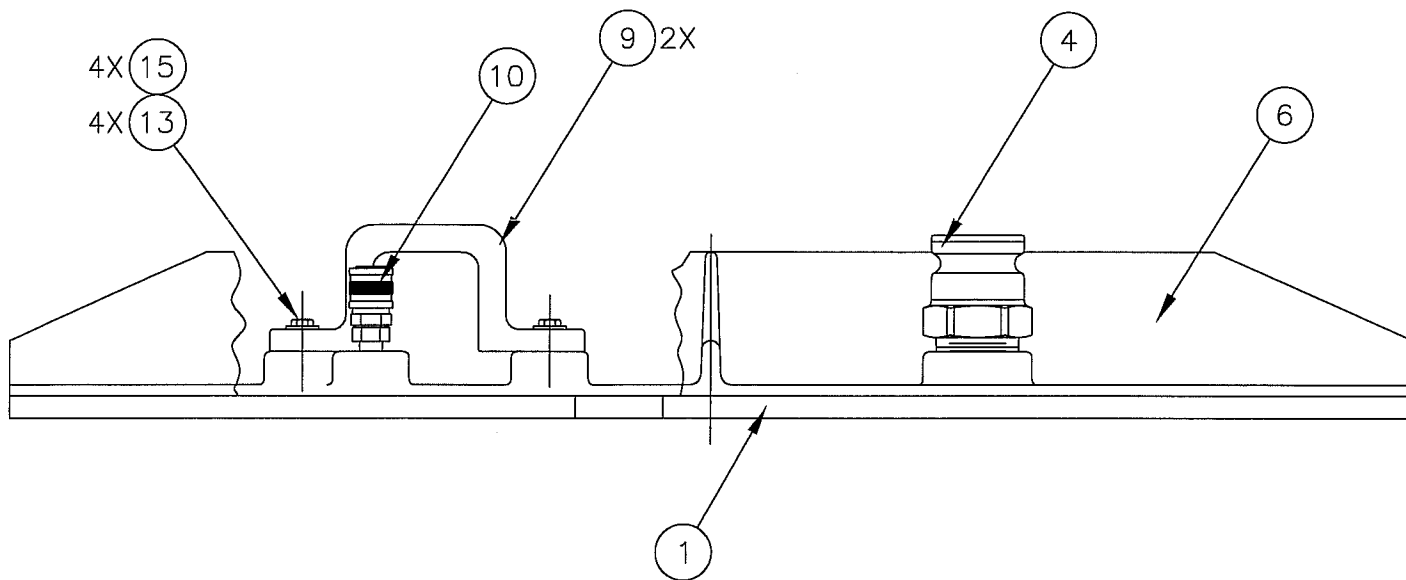

**PARTS LIST 38"  
ASSEMBLY #220-388**

ITEM	QUANTITY	PART NO.	DESCRIPTION
2	1	056-978	INSTRUCTION MANUAL (THIS MANUAL)
3	1	302-031	TEST PLATE, 38" MANHOLE
4	1	054-308	1-1/2" COUPLER, CAM AND GROOVE
10	1	054-978	1/4" QUICK COUPLER
13	1	002-518	BULKHEAD, 1/4 NPT
15	1	030-728	FOAM PAD, 38" DIAMETER
17	4	000-868	NUT, HEX, 1/4-20
18	4	086-274	SCREW, 1/4-20 1.25 FHM
19	4	000-132	WASHER, 1/4 LOCK
20	2	002-388	HANDLE, GRAB, 8" CENTERS-ZINC
21	1	055-348	1-1/2" VACUUM HOSE W/VACUUM GAUGE

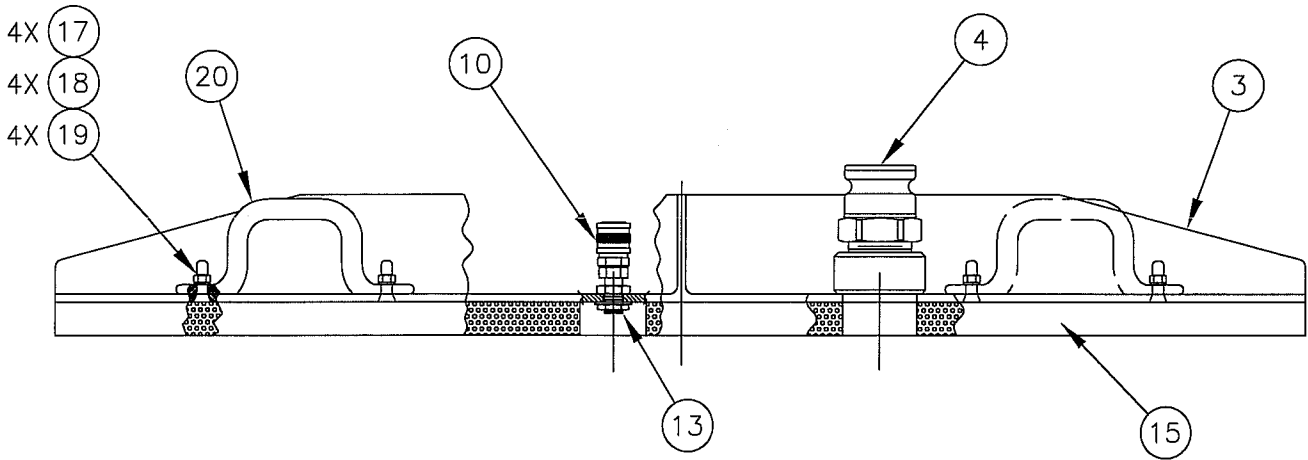



**PARTS LIST 44"  
ASSEMBLY #220-448**

ITEM	QUANTITY	PART NO.	DESCRIPTION
1	1	018-558	WELD ASSY, 44" PLATE STYLE M.T.
4	1	054-308	1-1/2" COUPLER, CAM AND GROOVE
10	1	054-978	1/4" QUICK-COUPLER
12	4.7FT	000-518	FOAM, 1" THICK
14	1	056-978	INSTRUCTION (THIS MANUAL)
17	2	002-388	HANDLE, GRAB, 8" CENTER-ZINC
18	4	086-274	SCREW, 1/4-20 1.25 FHM
19	4	000-132	WASHER, 1/4 LOCK
20	4	000-868	NUT, HEX, 1/4-20
21	1	055-348	1-1/2" VACUUM HOSE W/VACUUM GAUGE

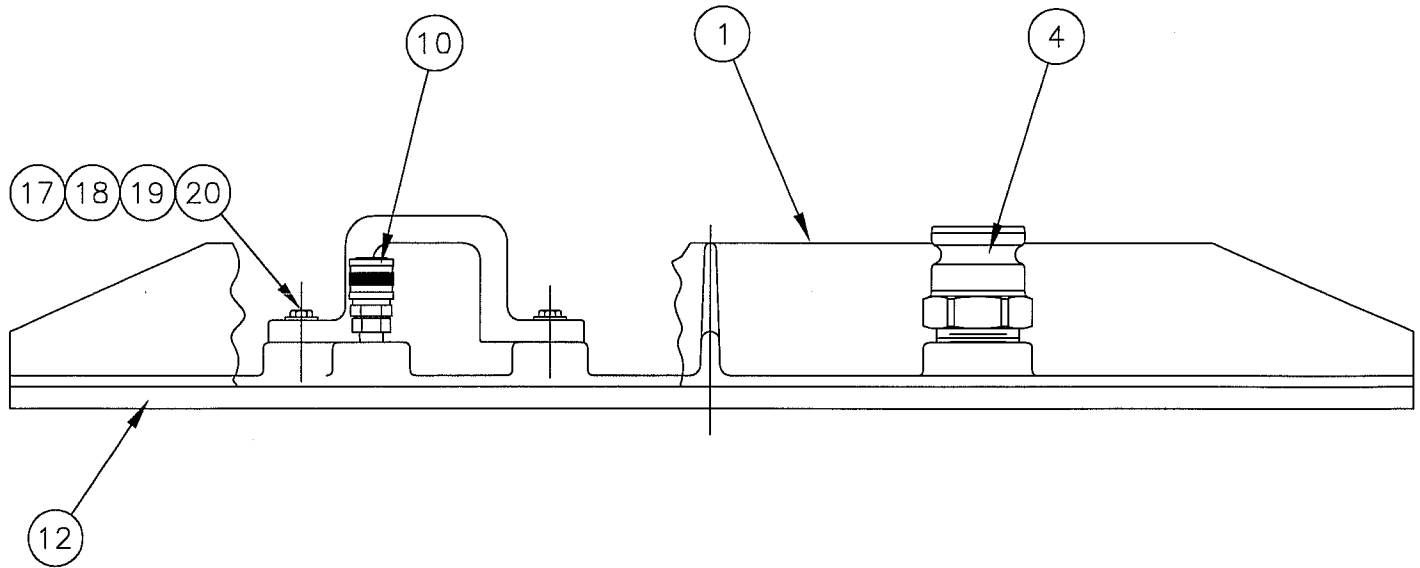

**PARTS LIST 1-1/2" VACUUM  
HOSE ASSEMBLY 055-348**

ITEM	QUANTITY	PART NO.	DESCRIPTION
1	1	055-348	1-1/2" VACUUM HOSE ASSEMBLY
4	1	055-418	COUPLER 1-1/2" HOSE BARB
6	1	055-338	VACUUM READBACK HOSE ASSEMBLY
7	1	251-623	NIPPLE, QUICK DISCONNECT 1/4"
9	1	304-058	VACUUM GAUGE

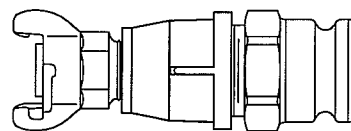
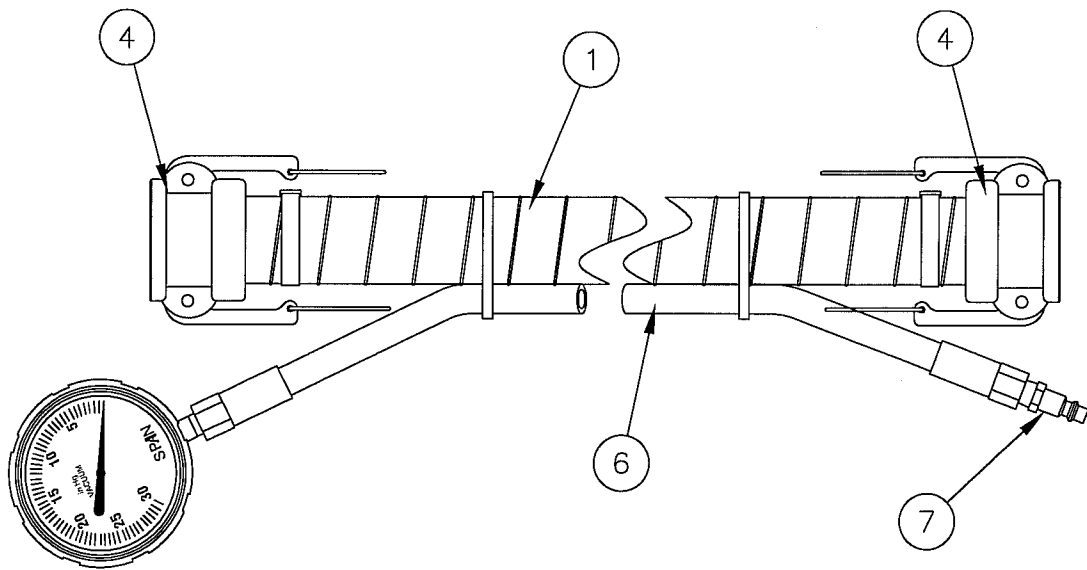

HOSE ADAPTER  
#055-398

**MANHOLE SAFETY PROCEDURE****RECOMMENDED SAFETY PROCEDURE FOR ENTRANCE INTO MANHOLES OR CONFINED SPACES**

**WARNING:** THESE RECOMMENDATIONS ARE TO BE USED AS A GENERAL GUIDELINE ONLY. ALTHOUGH CHERNE RECOMMENDS THESE FOLLOWING GUIDELINES, IT DOES NOT WARRANT, REPRESENT, OR ASSUME ANY RESPONSIBILITY THAT THESE RECOMMENDATIONS WILL FULFILL ALL APPLICABLE FEDERAL, STATE, OR LOCAL REQUIREMENTS. CHERNE ASSUMES NO LIABILITY FOR EITHER PERSONAL INJURY OR CONSEQUENTIAL DAMAGES THAT RESULT FROM THE RELIANCE ON THESE RECOMMENDATIONS.

**WARNING:** IT IS THE PRODUCT USER'S RESPONSIBILITY TO READ AND COMPLY WITH ALL APPLICABLE REGULATIONS. REFER TO THE CODE OF FEDERAL REGULATIONS, ""CFR" PART 1926 AND ALL OTHER PERTINENT FEDERAL, STATE, AND LOCAL REGULATIONS. ALWAYS OUTFIT YOURSELF WITH THE NECESSARY SAFETY EQUIPMENT FOR ENTRANCE INTO A MANHOLE OR CONFINED SPACE. THIS MAY INCLUDE, BUT NOT BE LIMITED TO, THE FOLLOWING ITEMS (REFER TO WARNING STATED IMMEDIATELY ABOVE):

Recommended equipment is as follows:

- |   |  |
|---|--|
| A. Safety Hat                                 | G. Ear Protection                              |
| B. Safety Glasses                             | H. Hazardous Gas Detector and Oxygen Monitor   |
| C. Respirator or Self-Contained Air Source    | I. Manhole or Confined Space Ventilation       |
| D. Safety Harness, Ropes, and Winching System | J. Protective Clothing                         |
| E. Safety Shoes or Boots                      | K. Safety Ladders                              |
| F. Protective Gloves                          | L. Any Other Recommended or Required Equipment |

**ALWAYS** ENSURE THAT ALL EQUIPMENT MEETS OR EXCEEDS THE MINIMUM REQUIREMENTS OF ALL APPLICABLE REGULATORY GUIDELINES. ALL EQUIPMENT SHOULD BE PROPERLY MAINTAINED, STORED, CALIBRATED IF NECESSARY, AND INSPECTED PRIOR TO EACH USE, IN COMPLIANCE WITH APPLICABLE REGULATIONS AND EQUIPMENT MANUFACTURERS RECOMMENDATIONS.

**ALWAYS** PROPERLY VENTILATE MANHOLE OR CONFINED SPACE BEFORE ENTERING AND MAINTAIN VENTILATION WHILE IN MANHOLE OR CONFINED SPACE.

**ALWAYS** THOROUGHLY CHECK AT ALL LEVELS FOR HAZARDOUS GASES AND PROPER OXYGEN LEVELS (20 % MINIMUM). CONTINUOUSLY MONITOR THESE LEVELS WHEN WORKERS ARE IN THE MANHOLE.

**NEVER** ENTER A MANHOLE OR CONFINED SPACE WITHOUT CO-WORKER ASSISTANCE. CO-WORKERS MUST BE PROPERLY TRAINED IN SAFETY REQUIREMENTS FOR ACCESS TO MANHOLES OR CONFINED SPACES.

**IF** YOU ENCOUNTER OR OBSERVE ANY CONDITIONS THAT ARE NOT EXPLAINED HERE OR NOT FULLY UNDERSTOOD BY YOU, NOTIFY YOU SUPERVISOR OR SAFETY DIRECTOR BEFORE PROCEEDING.

**ALWAYS** CONSULT WITH PROPER STATE, LOCAL, AND FEDERAL AGENCIES TO INSURE THAT ALL REQUIRED REGULATIONS ARE BEING FULFILLED.

**FAILURE TO COMPLY WITH PROPER SAFETY REGULATIONS MAY RESULT IN DEATH, SERIOUS BODILY INJURY AND/OR PROPERTY DAMAGE!**

## LIMITED WARRANTY

Manufacturer warrants all products manufactured by it will be free from defects in material and workmanship for one (1) year following the date of manufacture. If any of the goods are found to be defective, such goods will, at manufacturer's option be replaced or repaired at manufacturer's cost. The parties hereto expressly agree that buyer's sole and exclusive remedy against the manufacturer shall be for the repair or replacement of defective goods as provided herein. (The sole purpose of the stipulated exclusive remedy shall be to provide the buyer with free repair and replacement of defective goods in the manner provided herein. The exclusive remedy shall not be deemed to have failed of its essential purpose so long as the manufacturer is willing and able to repair or replace defective goods in the prescribed manner.) Goods which may be sold by manufacturer but are not manufactured by it are not warranted by manufacturer, but are sold only with the warranties, if any, of the original manufacturers thereof. (This warranty does not cover labor or other costs or expenses to remove or install any defective, repaired or replaced goods.) Manufacturer's warranty does not apply to any goods which have been subjected to misuse, mishandling, misapplication, neglect (including but not limited to use of unauthorized parts or attachments), or adjustment or repair performed by anyone other than manufacturer or one of manufacturer's authorized agents.

Any claim by buyer with reference to the goods sold hereunder shall be deemed waived by the buyer unless submitted in writing to manufacturer within the earlier of (1) thirty (30) days following the date buyer discovered or by reasonable inspection should have discovered, any claimed breach of the foregoing warranty, or (2) thirteen (13) months following the date of manufacture. Any cause of action for breach of the foregoing warranty shall be brought within one year from the date the alleged breach was discovered or should have been discovered, whichever comes first.

**LIMITATION OF LIABILITY.** Manufacturer's liability (whether under the theories of breach of contract or warranty, negligence, or strict liability) for its goods shall be limited to repairing or replacing parts found by the manufacturer to be defective, or at manufacturer's option, to refunding the purchase price of such goods or parts thereof.

**DISCLAIMER OF CONSEQUENTIAL DAMAGES.** In no event shall manufacturer be liable for consequential damages arising out of or in connection with this agreement, including without limitation breach of any obligation imposed on manufacturer hereunder or in connection herewith. Consequential damages for purposes hereof shall include, without limitation (including death) to any person, or loss of or damage to property (including without limitation property handled or processed by the use of goods). Buyer shall indemnify manufacturer against all liability, cost or expense which may be sustained by manufacturer on account of any such loss, damage or injury.

**DEFECTIVE PRODUCTS POLICY.** To obtain performance under this warranty, any product suspected of having a manufacturing defect in materials or workmanship at manufacturer's request must be returned to CHERNE INDUSTRIES INCORPORATED, freight prepaid, for inspection. A returned goods authorization must be obtained before shipping any product back to CHERNE. Call 1-800-843-7584 and ask for customer service.

**CUSTOMER TRANSPORTATION REIMBURSEMENT.** Whenever CHERNE repairs or replaces a product at CHERNE'S expense CHERNE will reimburse the distributor by credit memo, the same surface freight amount it cost CHERNE to return the warranty items.

The foregoing warranty is in lieu of all other warranties express or implied, including those of merchantability or fitness for any purpose not expressly set forth herein. No affirmation of manufacturer, by words or action, other than as set forth in this language shall constitute a warranty.